

This drawing is the Property of GLEN DIMPLEX AUSTRALASIA LTD. All dimensions are outside/outside unless otherwise stated.

Item Number	Document Number	Title	Material	Quantity
1*	ECSAC103	FIRE BOX ASSEMBLY		1
2	ECS00633	SIDE BRICK BACK	Vermiculite	1
3	ECS00632	SIDE BRICK MIDDLE	Vermiculite	1
4	ECS00630	SIDE BRICK FRONT	Vermiculite	1
5	ECS00743	GRATE FRENCH		2
6	ECSAC110	BAFFLE PLATE ASSY WB		1
7	ECS00555	COAL BAR	Cast Iron	1
8	ECSWBRE	WATER BOOSTER REAR ENTRY		1

PART NUMBER : ECS_SPARES_WB			REVISION LEVEL :
Amendment	Date	By	TOLERANCES : Decimal Places: 0 ± 0.5 0.0 ± 0.2 Angles Degrees: 0 ± 5°

NOTES:
 1) ALL BURRS AND SHARP EDGES TO BE REMOVED.
 2) TO BE NO RUST ON BASE METAL.

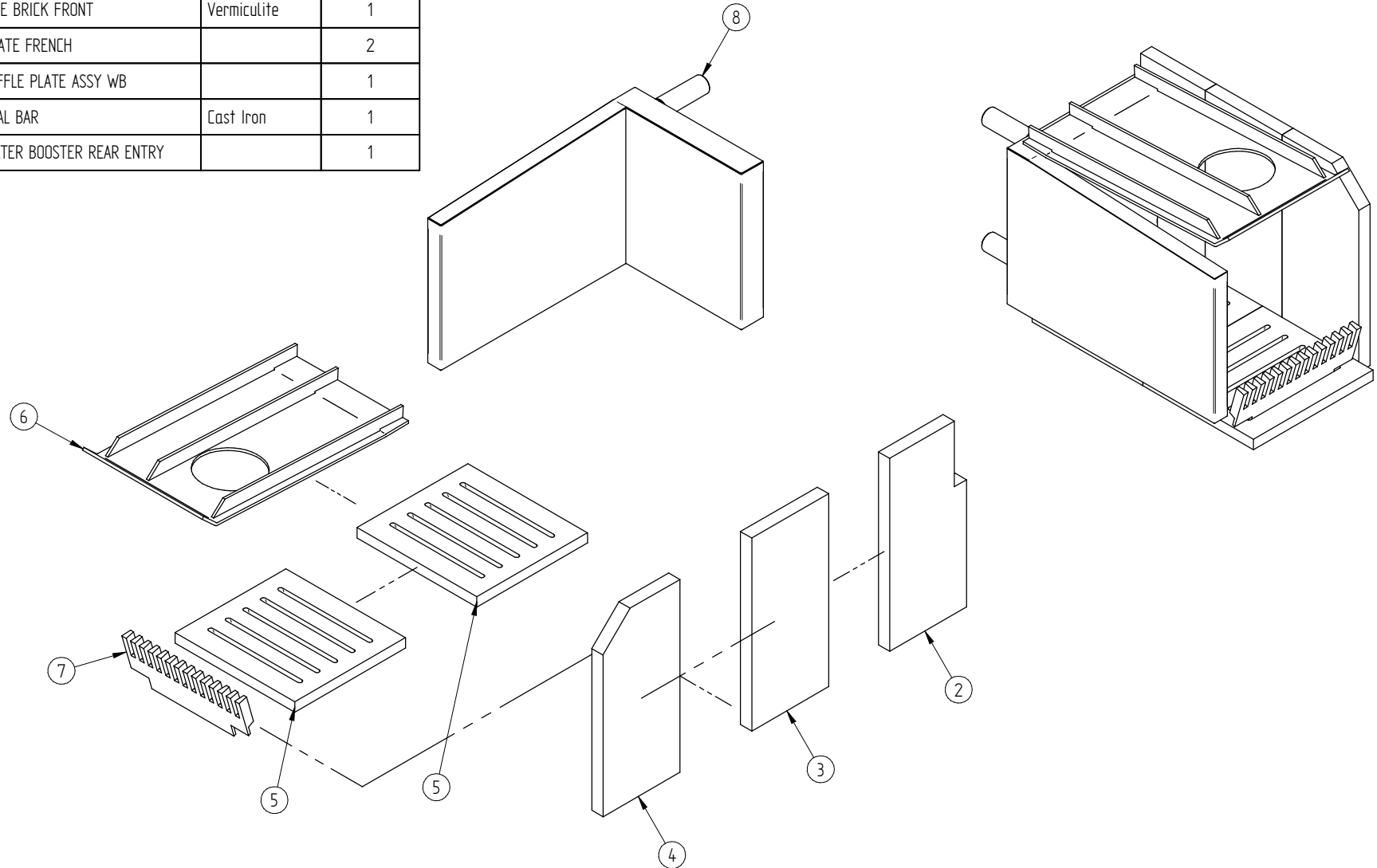

GLEN DIMPLEX AUSTRALASIA LTD
 38 HARRIS ROAD, EAST TAMAKI, AUCKLAND, NEW ZEALAND
 Ph 09 274 8265, Fax 09 274 8472, Email : Eng_Office@glendimplex.co.nz

Customer : ESSE	Drawing No :	Drawn : jimmc	Date : 17/03/2008	Chk'd By :
Part Name : SPARES WATER BOOSTER	Material :	Modified : jimmc	Date : 17/03/2008	
				Finish : Natural